

Instructions for use

Plastic site road

Date: August 2022

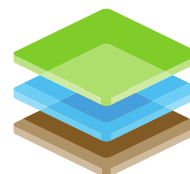

terra
infrastructure



Information about the instructions for use

These instructions enable the safe handling of the plastic site road. The instructions are an integral part of the system and must be kept in the immediate vicinity of the construction site so that they are always accessible to the personnel.

The personnel must have read and understood these instructions carefully before starting any work. The basic prerequisite for safe working is compliance with all safety instructions and instructions for action given in these use instructions.

In addition, the local occupational safety regulations and general safety regulations for the area of application apply.

All safety-related dimensions conform with German safety and accident prevention regulations and German standards. The respective state-specific regulations are to be checked and applied before the works start.

Contents

1	System overview	2
2	Occupational safety and general notes	3
2.1	Symbols used in these instructions for use.....	3
2.2	Threats	4
2.3	General safety instructions and measures to reduce hazards.....	4
2.4	Protection against load fall and falling parts	5
2.5	Storage, transport and lifting operations.....	5
2.6	Criteria for inspection, maintenance and rejection of worn or damaged components	6
2.7	Applicable regulations	6
2.8	Personal protective equipment	7
2.9	Technical data of the shoring elements.....	7
3	Installation instructions	8

1 System overview

Plastic site road

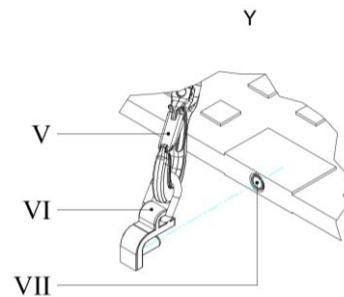
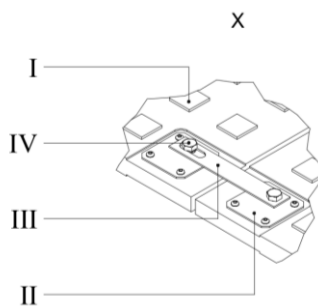
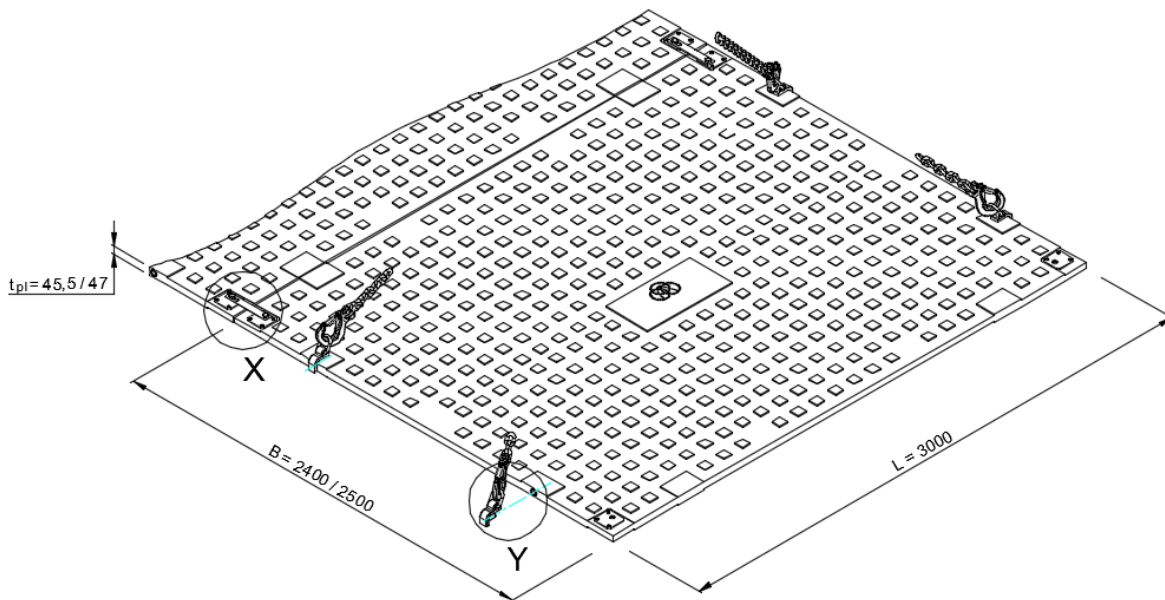

(All dimensions in mm)

I	Plastic site road	B	Width
II	Plastic site road connector edge	L	Length
III	Plastic site road connector	t_{pl}	Panel thickness
IV	M16 screw		
V	Four-strand chain		
VI	Plastic site road sling		
VII	Lifting socket		

2 Occupational safety and general notes

2.1 Symbols used in these instructions for use

Safety instructions

The following occupational safety symbols are located next to all occupational safety instructions that indicate a danger to life and limb of persons and are identified by a pictogram, a signal word and a signal colour.

The documentation explains the danger situations at the relevant points.

Observe these notes!

Observe the locally applicable safety and accident prevention regulations!

All the following dimensions conform with German safety regulations.

DANGER



Type and source of the danger

This symbol warns of a direct danger to the life and health of persons.

Non-observance of these instructions will result in serious health effects up to life-threatening injuries and extensive damage to property.

Action that must be omitted to prevent the danger from occurring.

WARNING



Type and source of the danger

This symbol warns of an imminent danger to the life and health of persons as well as damage to the environment and property.

Non-observance of these instructions can result in serious health effects up to life-threatening injuries or extensive damage to the environment and property.

Action that must be omitted to prevent the danger from occurring.

CAUTION



Type and source of the danger

This symbol warns of an imminent danger to the health of persons as well as damage to the environment and property.

Non-observance of these instructions can result in medium or slight health effects up to injury or extensive damage to the environment and property.

Action that must be omitted to prevent the danger from occurring.

NOTICE



Type and source of the damage to machinery and equipment

This symbol warns of a dangerous situation and is used to indicate a notice on how to handle the plastic construction road.

Failure to observe these notices can lead to extensive damage to property.

Action that must be omitted to prevent damage from occurring.

Tips and recommendations



This symbol highlights useful tips and recommendations as well as information for efficient and trouble-free operation. Action that must be omitted to prevent the danger from occurring.

Other markings

The following markings are used in this manual to highlight instructions, results, listings, references and other elements:

Marking	Explanation
1., 2., 3. ...	Step-by-step instructions for action
	Action results
	Lists without fixed order

2.2 Threats

When working with the construction road, during loading and unloading, and when laying the panels, the following hazards exist, among others, with possible serious injuries or fatal consequences:

- Injuries due to suspended/swivelling loads
- Stumbling, slipping, falling
- Being hit by falling parts
- Crushing of hands and feet during loading and unloading, transport, assembly and disassembly and when laying out the panels

2.3 General safety instructions and measures to reduce hazards

We would like to point out that before assembly and disassembly of the panels, a corresponding risk assessment for the above-mentioned work steps must be prepared.

It is imperative that the technical information and the safety notices in these use instructions are followed.

DANGER



Danger to life or risk of injury due to inadequate protection of the construction site and neighbouring facilities/trades!

Inadequate protection of the construction site may result in serious or fatal injuries.

- Damage to buildings, vehicles, objects and persons located in the work area must be prevented by appropriate measures (e.g. sufficient safety distances).
- The panels are not suitable for bridging trenches, large differences in height or large holes.
- The use instructions must be available at the construction site.
- The construction road must be laid out by qualified personnel.
- The stability of the transport and laying machines must be ensured.
- The accessories, in particular the load carrying and/or slinging equipment, as well as the corresponding attachment points must be checked for damage and defects before work is started. Work may only begin when all defects have been eliminated.
- If the panels are laid by means of a forklift truck, the conditions on site must be checked in particular; especially a stable, level surface must be ensured.
- Ensure traffic safety if panels are laid in the area of public road traffic or if the laying has an impact on road traffic. Consult with the competent authorities.
- Two persons are always required to lay the panels.
- There is a speed limit of 10 km/h for all vehicles on the construction site road.
- Due to the material-related thermal expansion coefficient, large temperature differences can cause the plastic site road panels to expand in length.

Tips and recommendations



- A traffic safety is to be realized e.g. by means of barks or specially assigned security personnel.
- The construction site is to be adequately marked as such, e.g. by means of warning signs.
- The working area of the panel laying machine (excavator, forklift, telescopic loader, wheel loader or similar) must be signposted as such and secured over a large area.

2.4 Protection against load fall and falling parts

DANGER



Danger to life or risk of injury due to persons or parts falling down!

Persons or parts falling down may cause danger to life or risk of injury as well as damage to property! The following measures must be implemented depending on the construction site:

- Sufficient protection of the working area.
- The panels must be attached with an approved and tested 4-strand chain sling. Ensure that the safety hook is intact.
- The panels are to be fastened with an approved and tested 4-strand chain hanger. Make sure that the hook safety catch is intact. The length of the chain hanger should be selected so that the bracket is in the permitted area (between 45° and 60°).
- If the panels are laid using a forklift truck, an additional load handling device is required which is attached to the forklift fork. The chain sling must be hooked into the load hook of the load handling device.
- When using vacuum lifters, it is essential to ensure that the surface of the panels is free of dirt and/or other adhesions. If necessary, the panels must be cleaned beforehand.
- The panels should be kept as close to the ground as possible.
- Before the disassembly of the panels, the top side must be cleaned properly.
- When disassembling the panels, materials adhering to the underside may come loose and fall off during the lifting and swivelling process.
- When laying the plastic construction road, the minimum distances (protective areas) around the upper edge of the pit or trench must be observed.
- Falling down of the panels during the lifting process must be prevented by properly inserting the slings.
- Care must be taken to ensure that the panels are free of falling materials (tools, screws, connectors, etc.) during lifting and swivelling.
- Do not step under suspended loads.

2.5 Storage, transport and lifting operations

Storage

DANGER



Danger to life or risk of injury due to incorrect storage!

Incorrect storage may result in danger to life or risk of injury as well as damage to property.

- The panels may only be stored on firm and level ground.
- The prescribed safety distances to pit and trench walls must be strictly observed during storage.
- The load-bearing capacity of the underground must be ensured before storage.
- The panels may only be stacked neatly in a maximum of 8 stacks of 5 panels each after having been cleaned. Between the stacks of 5 panels, 3 squared timbers (10 cm x 10 cm) must be placed underneath each of them at intervals of one third.

Transport and lifting operations

DANGER



Danger to life or risk of injury due to suspended loads!

During lifting operations, loads may swing out and fall down. There is danger to life or risk of injury and damage to property.

- Cranes or hydraulic excavators should preferably be used for transport/laying in hoist mode; when transporting with forklift trucks, it must be taken into account that the ground in the construction site area is often uneven. This can lead to the load slipping or falling - additional safety measures may be necessary when transporting with forklift trucks.
- The panels must be cleaned before transport.
- Transport damage must be reported to the manufacturer immediately.

- If the panels are laid using a forklift truck, a load handling device is required which is attached to the fork.
- Hydraulic excavators in hoist operation must be equipped with an overload warning device and line breakage protection; the overload warning device must be switched on in hoist operation.
- Lifting gear, load handling devices and slings must be selected according to the load.
- All lifting gear, load stops and load handling devices must be approved and tested.
- Only load hooks with a safety latch must be used to prevent the load from unintentionally unhooking when lifting, pulling or transporting.
- The panels may only be attached and transported at the designated attachment points.
- Pendulum movements during transport must be reduced to a minimum.
- Transport must be carried out as close to the ground as possible.
- Never pass the lifted load over persons.
- Attached loads are to be guided with guide ropes/guiding rods; always walk behind the load and do not walk backwards.
- Accompanying persons for guiding the load and lifting gear must always be inside of the machine operator's field of vision and outside of the travel path or danger zone.
- Accompanying persons for guiding the load and lifting gear must have a safe standing position; never stand between a suspended load and a fixed abutment (danger of crushing!).
- Always ensure that fingers and feet are free when lifting, guiding and setting down the load; never guide loads by the lifting.
- Unauthorised persons must be prevented from entering the working and swivel area (danger zone). If necessary, the transport and loading area must be shut-off or secured by a security guard.

2.6 Criteria for inspection, maintenance and rejection of worn or damaged components

- The panels are subject to a functional test and visual inspection by the supervisor prior to each use. Attention must be paid to conspicuous defects such as fractures, defective attachment points and gross damage.
- If defects are found that might reduce the load-bearing capacity, especially damaged attachment points, the panels may only be reused after they have been properly repaired.
- Defective or missing parts must be exchanged, repaired or replaced before use.
- Only original parts from the manufacturer are to be used.
- The manufacturer does not grant any warranty for any repairs carried out independently and when using parts that are not original parts.
- In case of any doubts about the usability of the panels, in case of defects and damages, the manufacturer is to be contacted.

2.7 Applicable regulations

The applicable national rules and regulations must be observed and complied with.

2.8 Personal protective equipment

Personal protective equipment (PPE) is designed to protect people from adverse effects on safety and health at work.

Basically, the personal protective equipment required for the activities is the result of your risk assessment.

We recommend the following PPE for loading and unloading activities, assembly and disassembly, transport and lifting activities, maintenance and repair and cleaning:

PROTECTIVE WORK WEAR



Protective work wear is close-fitting work wear with low tear resistance, with tight sleeves and without protruding parts.

SAFETY HELMET



Safety helmets protect the head against falling objects, swinging loads and bumping into stationary objects.

PROTECTIVE GLOVES



Protective gloves are used to protect the hands from friction, abrasions, punctures, cuts or deeper injuries.

SAFETY SHOES



Safety shoes protect the feet from crushing, falling parts and slipping on slippery surfaces. In addition, S3 safety shoes are puncture-resistant and thus protect against foot injuries caused by nails, metal chips, etc.

2.9 Technical data of the shoring elements

The technical data of the shoring elements used can be found in the current version of the technical manual. The technical manual is available at www.terra-infrastructure.com

3 Installation instructions

Before starting work, all safety instructions in the chapter "Occupational safety and general notes" must be observed (see chapter 2 on page 3)!

Depending on the application of the plastic site road, different profiles must be used.

- The 2.5 mm surface profile is suitable for pedestrian traffic, for example.
- The 5.0 mm surface profile is suitable for construction machinery, truck and car traffic, for example.

At least 2 persons are required for the laying (1 driver and 1 helper).

The following installation instructions apply to all panel sizes:

1. Laying

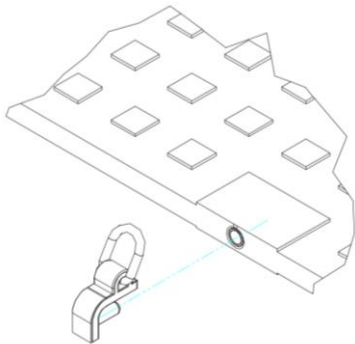

Laying is carried out using suitable lifting gear and slings (4-strand chain with GS approval).

The respective mandrels of the four slings are to be completely inserted into the lifting sockets.

2. Inserting the load hooks

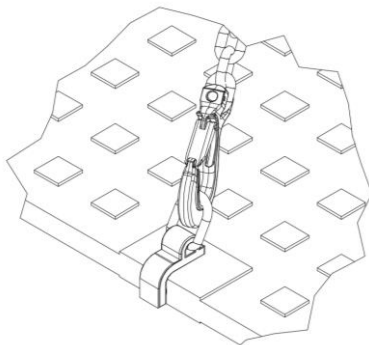

Then the load hooks of the chain sling must be hooked into the suspension rings of the sling gear.

The closed position of the safety latch must be checked.

3. Positioning

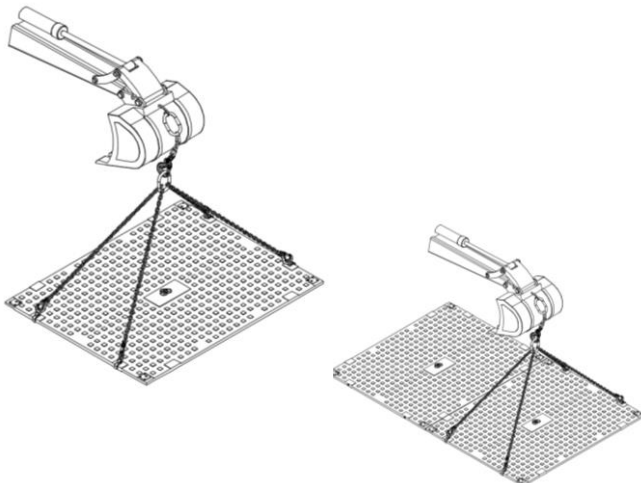

The site road panel can now be positioned. For this purpose, it should be moved as close to the ground as possible, in a horizontal position. Make sure that no persons are in the danger zone or swivel area.

In order to be able to connect the individual site road panels with each other without any problems, they should be laid as close to each other as possible and flush with each other.

4. Connection

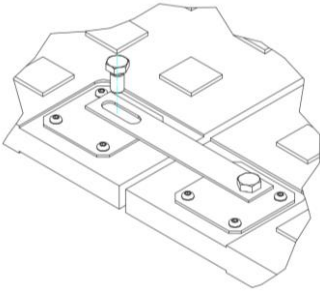

The panels are connected by means of metal connectors and hexagon head screws. First the metal connector is connected to the panel in the circular hole by a screw. Then the screw is mounted in the slotted hole.

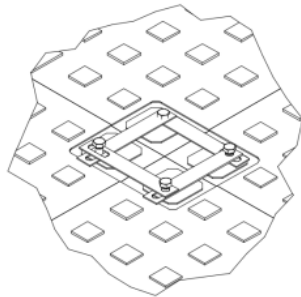

If the panels are laid over a larger area, the panels are fastened to each other in a clockwise sequence.

5. Passing over

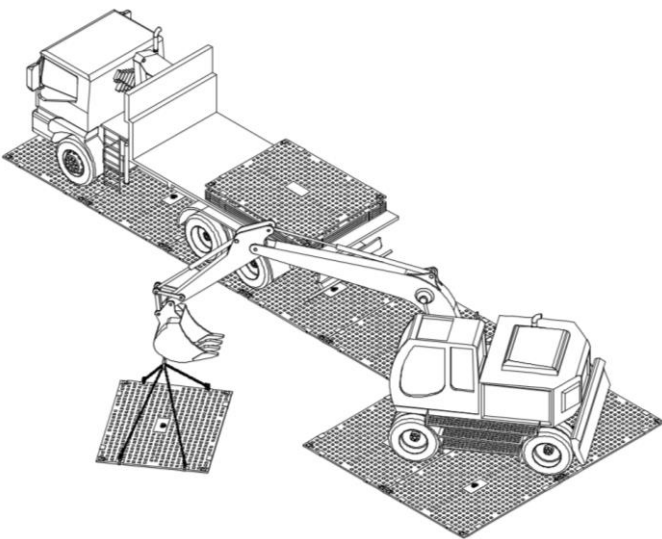

The site road panels can be laid continuously and can be passed over after fixing. Passing over with crawler type vehicles is only permitted with rubber tracks and requires prior instruction.

terra infrastructure

terra infrastructure GmbH
Hollestraße 7a
45127 Essen, Germany
P: +49 201 844 - 562313
F: +49 201 844 - 562333
info@terra-infrastructure.com
www.terra-infrastructure.com

Trench Shoring

terra infrastructure GmbH
Ottostr. 30
41836 Hückelhoven, Germany
P: +49 2433 453-0
F: +49 2433 453-100
trenchshoring@terra-infrastructure.com