



## SYSTEM TERRA TK 100 ALUMINUM FLOOD PROTECTION SYSTEM TECHNICAL DATA

### Flood protection:

#### Urgent need for action.

People have settled near rivers and coasts for thousands of years. Over the past few centuries river courses have been straightened and constricted, flood plains reclaimed and built on, and forests cut down. The consequences of these human interventions are climate change and an increasing number of environmental disasters. Floods, formerly once-in-a-century events, are occurring more and more frequently.

Experts are agreed that urgent action is needed: flood damage already tops the European loss statistics. Some of the losses are foreseeable and can be prevented by flood protection measures matched to local requirements. Flood protection and prevention are therefore among the most urgent tasks facing the local communities concerned.

#### End-to-end competence.

terra infrastructure is a world-renowned supplier of flood protection equipment. We offer a broad spectrum of high-quality products and diverse technical services in hydraulic engineering and water management.

### Content

<b>01</b>	<b>Flood protection systems</b>
02	Flood protection wall
03-04	Gap closure
<b>02</b>	<b>Post, stop log</b>
05	Load cases
06-10	Post height and stop log length
<b>03</b>	<b>Anchor plate systems</b>
11-14	Anchor plate AP 100 T1 – T4
<b>04</b>	<b>Wall connecting post</b>
15	Connecting with concrete anchor
16	Connecting with screw
<b>05</b>	<b>Corner post, Anchor plate</b>
17	Corner post
18-19	Anchor plate 90 degree
<b>06</b>	<b>Special systems</b>
20-23	System pocket foundation
24-26	Connection to the sheet pile
<b>07</b>	<b>Sealing</b>
27	Base – post - and stop log sealing
<b>08</b>	<b>Locking system</b>
28	Stop log locking system
<b>09</b>	<b>Storage system</b>
29	Storage boxes for stop logs and posts

## Flood protection wall

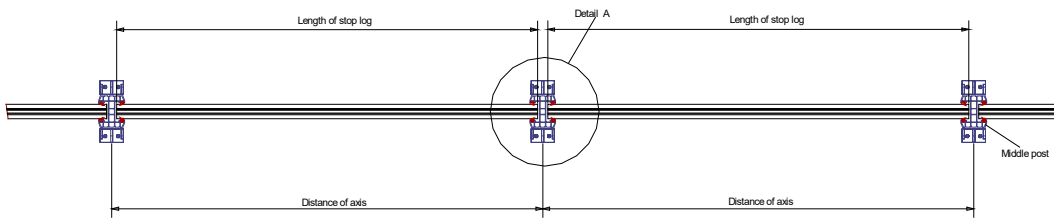
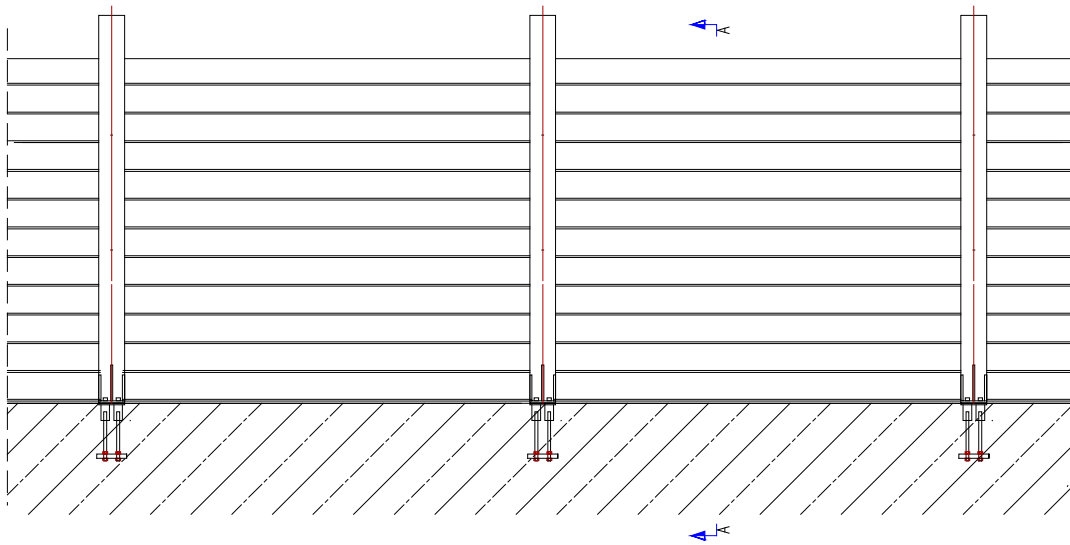

Detail A

Cross section A-A

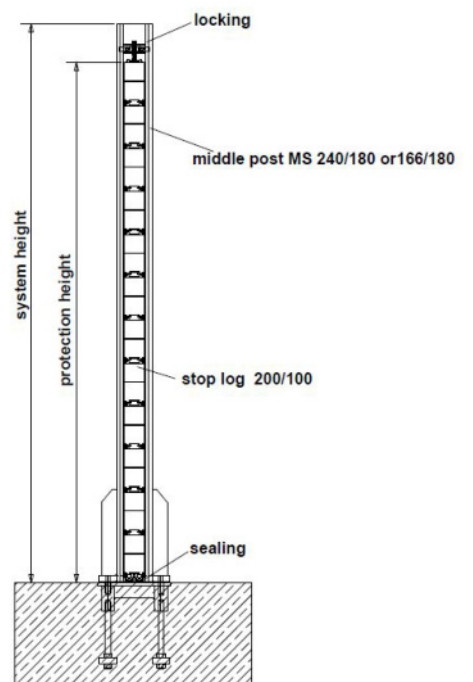
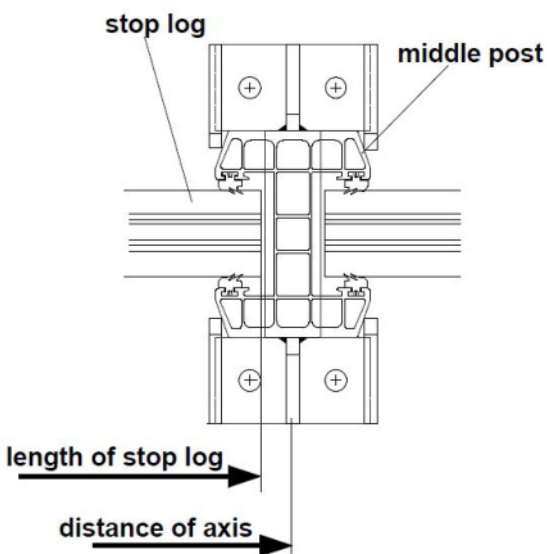

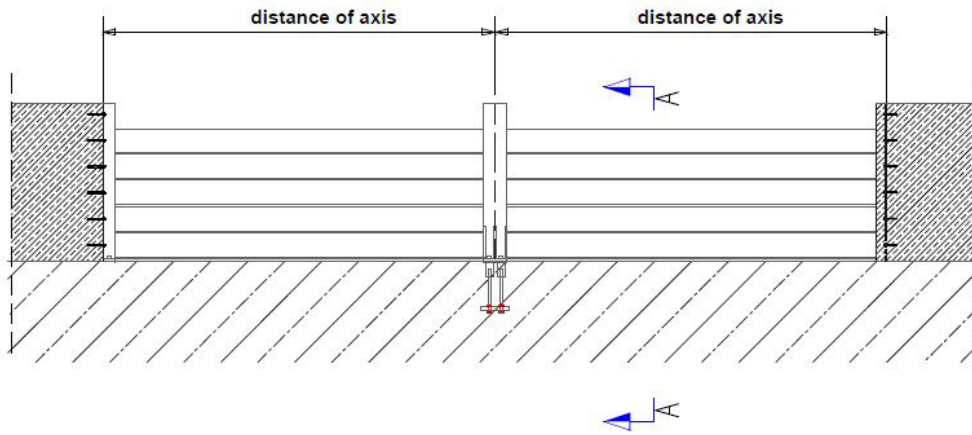

wall connector profile WA 80/169

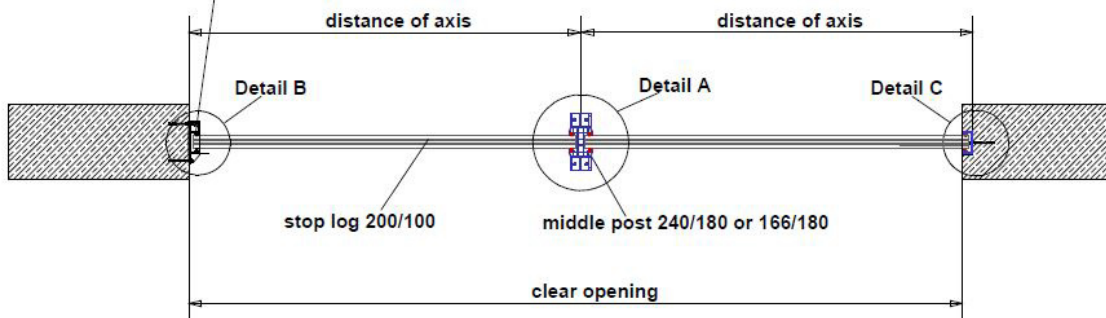

Detail B

Detail A

Detail C

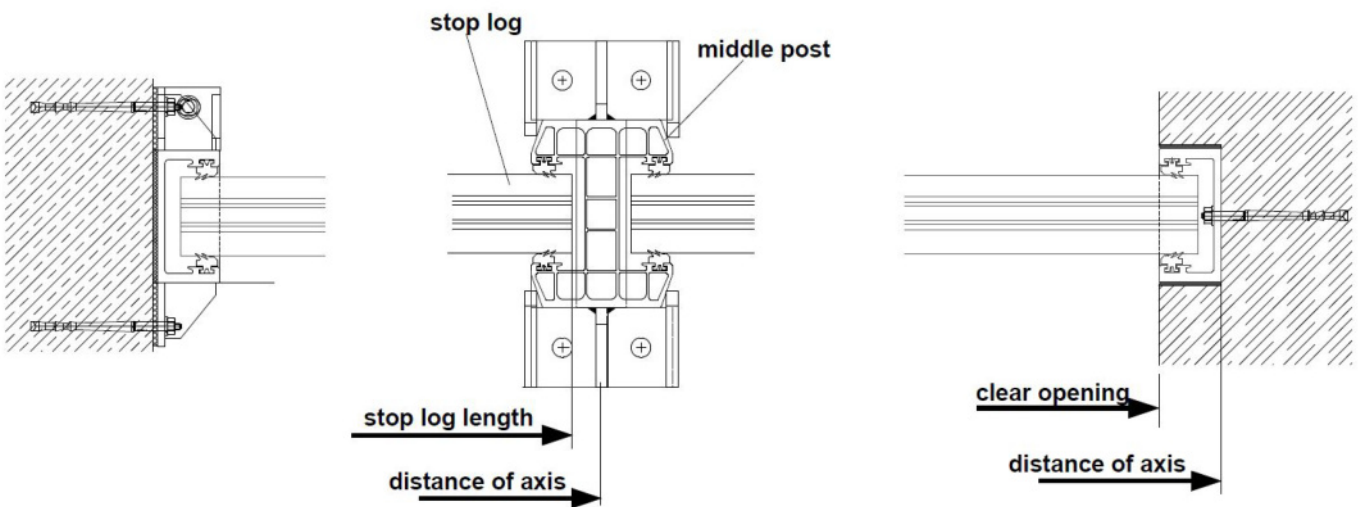

## Two load cases

### Load case water pressure

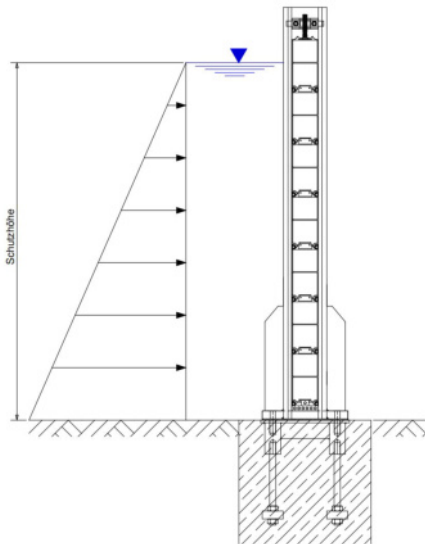

Hydrostatic water pressure with a weight density of 10 kN/m<sup>3</sup> and a safety factor of 1,35.

Further loads as flow pressure, wave impact, ice impact, vehicle impact and load of people are not considered here.

### Stop log height

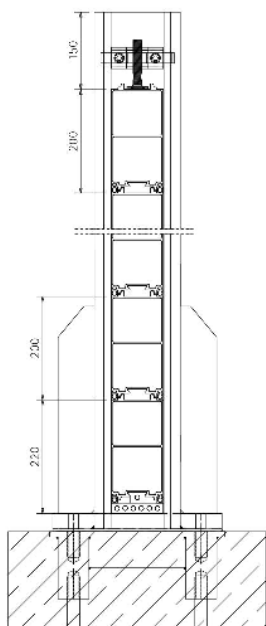

### Load case water pressure and impact load

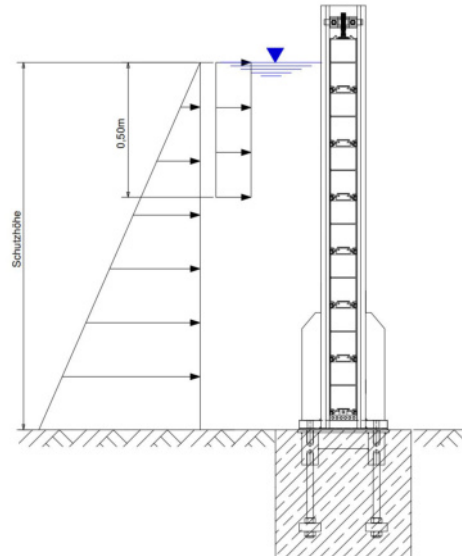

In addition to the hydrostatic water pressure an impact load of 20 kN on an area of 50cm x 50cm should be considered.

#### System 100 x 200

Numbers of stop log	Protection height mm	Post height mm
1	220	370
2	420	570
3	620	770
4	820	970
5	1020	1170
6	1220	1370
7	1420	1570
8	1620	1770
9	1820	1970
10	2020	2170
11	2220	2370
12	2420	2570
13	2620	2770
14	2820	2970
15	3020	3170

Aluminum stop log SL 200x100 L  
(on request)

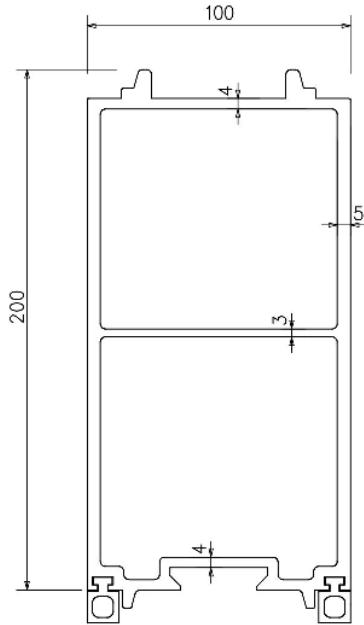

Daten

Moment of inertia	I	520.3 cm <sup>4</sup>
Section modulus	W	104 cm <sup>3</sup>
Cross section	A	32.23 cm <sup>2</sup>
Weight		8.70 kg/m
Material		EN AW-6063 [AlMg0,7Si] T66

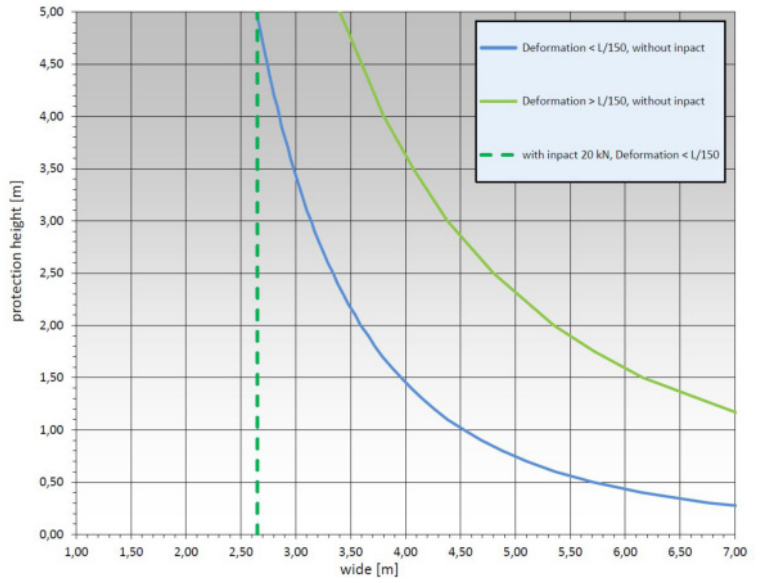

Aluminum stop log SL 200x100 S

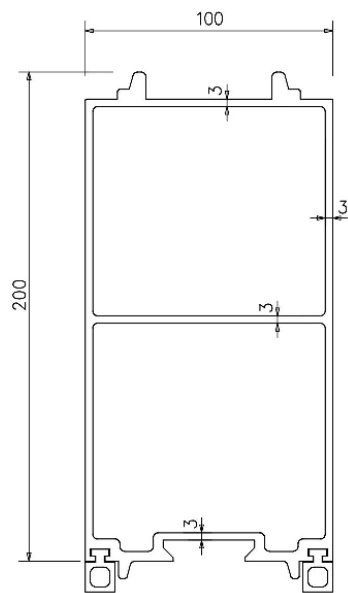

Daten

Moment of inertia	I	366.5 cm <sup>4</sup>
Section modulus	W	73.3 cm <sup>3</sup>
Cross section	A	24.00 cm <sup>2</sup>
Weight		6.47 kg/m
Material		EN AW-6063 [AlMg0,7Si] T66

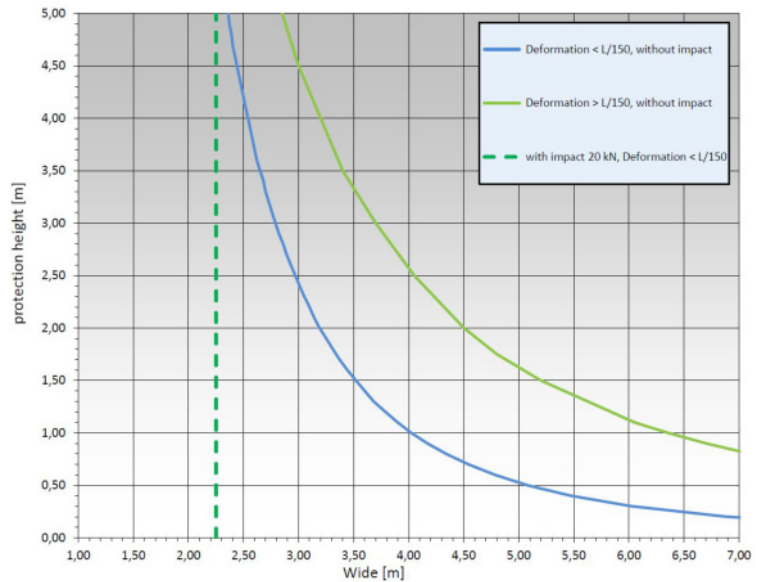

Post MP 166 x 180

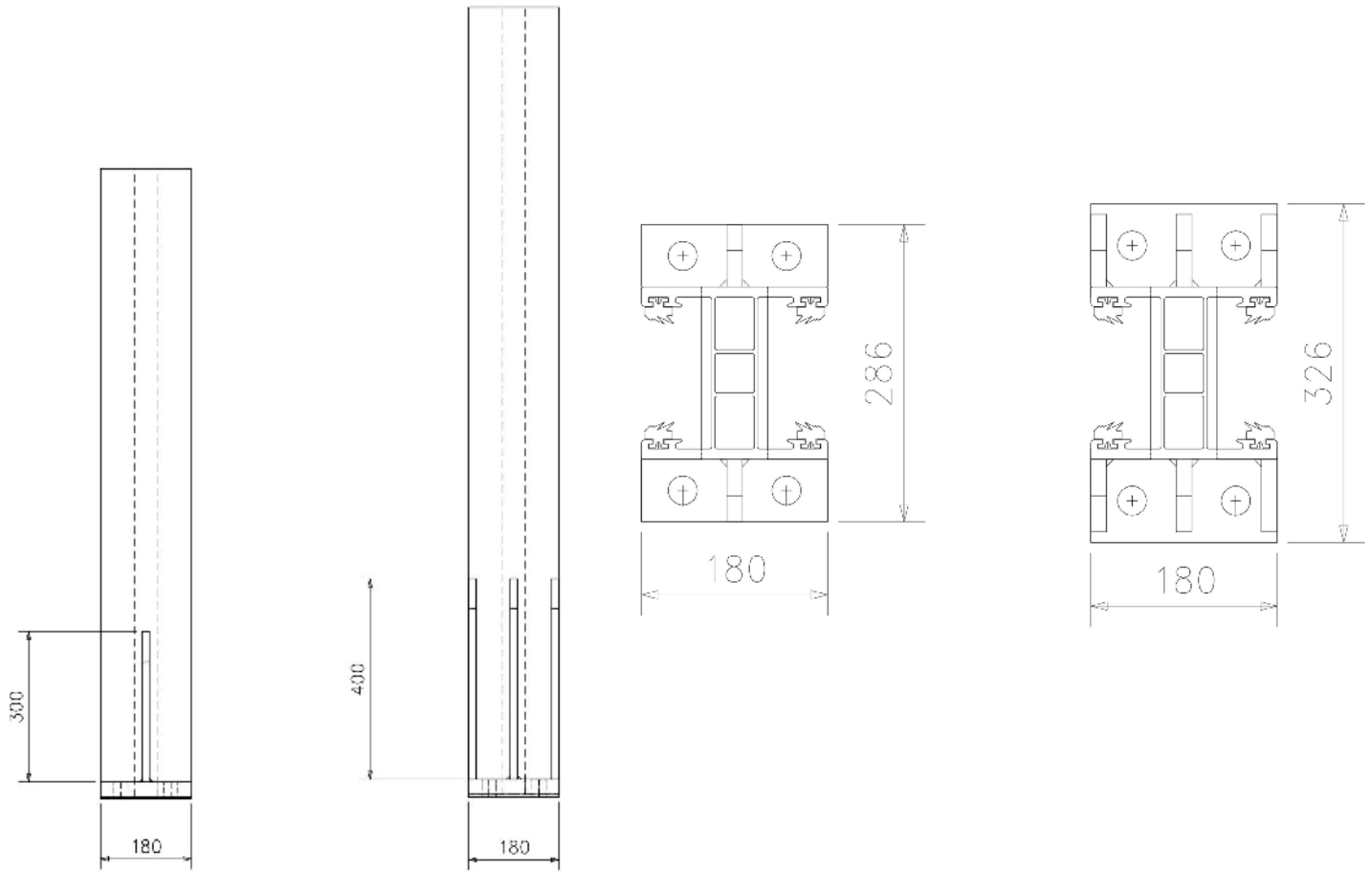

	Height (mm)	max. wide (mm)	Weight (kg)	Anchor plate
MS 166x180 S	200	6000	10.51	300x200
	400	6000	13.43	
	600	6000	16.35	
	800	5000	19.27	
	1000	4000	22.18	
	1200	3500	25.11	
	1400	3000	28.03	
MS 166x180 L	1600	3000	32.65	340x200
	1800	3000	35.57	
	2000	2500	38.49	

Daten		
Moment of inertial	I	2679 cm <sup>4</sup>
Section modulus	W	323 cm <sup>3</sup>
Cross section	A	54.06 cm <sup>2</sup>
Weight		14.6 kg/m
Material		EN AW-6082 [AlMgSi1] T6

(Posts are calculated as a freestanding system, with back supports, greater protection heights are possible)

## Post MP 240 x 180

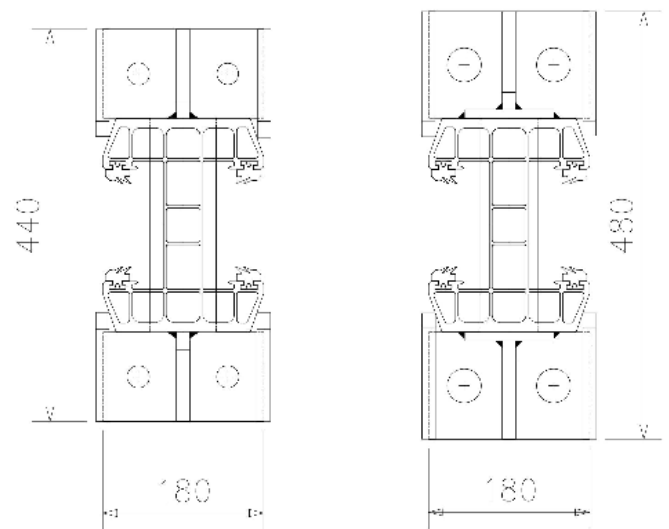
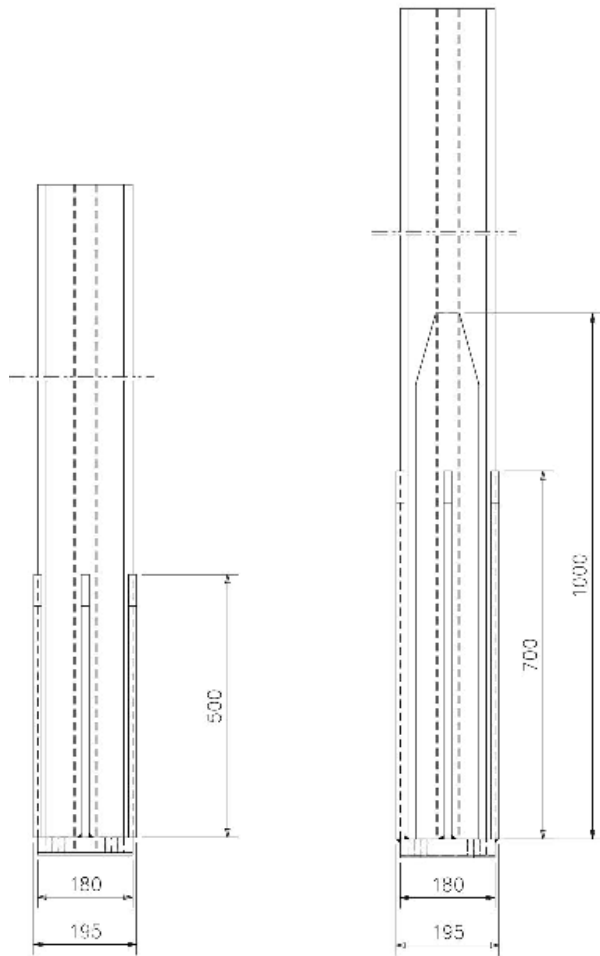

	Height (mm)	max. wide (mm)	Weight (kg)	Anchor plate
MS 240x180 S	1200	6000	38.93	440x200
	1400	5500	43.31	
	1600	5000	47.54	
	1800	4500	52.07	
	2000	3500	56.45	
	2200	3000	60.53	
MS 240x180 L	2400	2500	65.21	480x200
	2600	3000	70.72	
	2800	2500	75.10	
	3000	2000	79.84	

Daten		
Moment of inertial	I	7125 cm <sup>4</sup>
Section modulus	W	594 cm <sup>3</sup>
Cross section	A	80.96 cm <sup>2</sup>
Weight		21.9 kg/m
Material		EN AW-6082 [AlMgSi1] T6

(Posts are calculated as a freestanding system, with back supports, greater protection heights are possible)

Anchor plate: AP100 T1 - View A-A

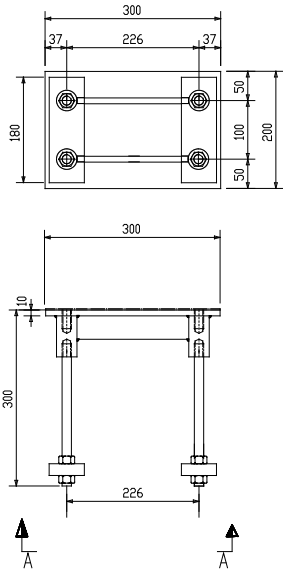

Steel grades

Stainless steel	1.4301	Top plate / threaded sleeve
Steel	S 355	Connecting plate
Steel	8.8	Threaded bolt / Nuts
Weight	24.49 kg	

Anchor plate: AP100 T2 - View A-A

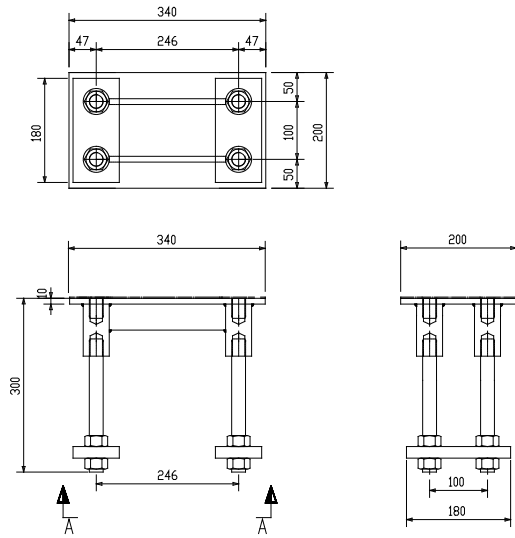

Steel grades

Stainless steel	1.4301	Top plate / threaded sleeve
Steel	S 355	Connecting plate
Steel	8.8	Threaded bolt / Nuts
Weight	29.77 kg	

Anchor plate: AP100 T3 - View A-A

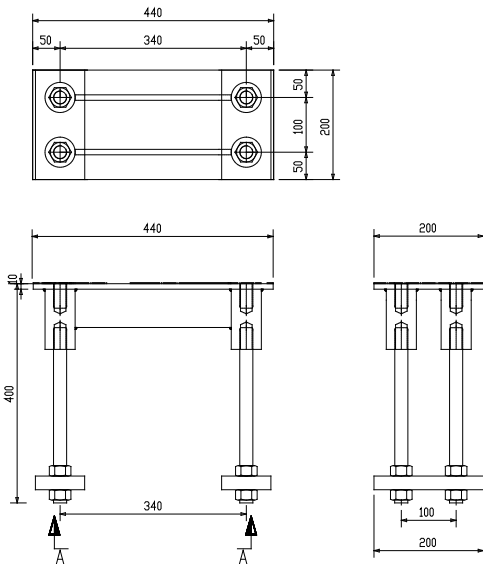

Steel grades

Stainless steel	1.4301	Top plate / threaded sleeve
Steel	S 355	Connecting plate
Steel	8.8	Threaded bolt / Nuts
Weight	38.53 kg	

Anchor plate: AP100 T4 - View A-A

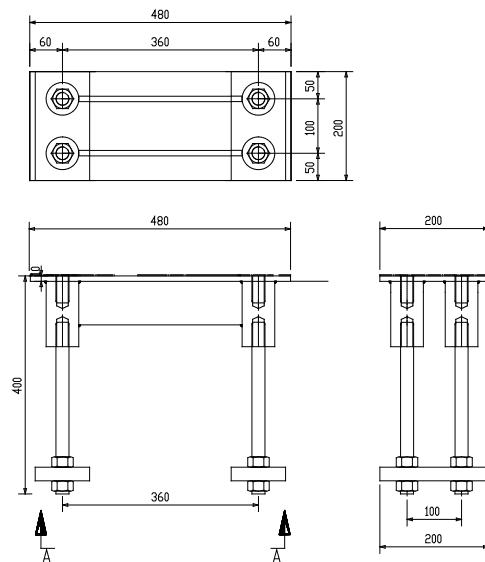

Steel grades

Stainless steel	1.4301	Top plate / threaded sleeve
Steel	S 355	Connecting plate
Steel	8.8	Threaded bolt / Nuts
Weight	47.86 kg	



Wall connecting post  
(Embedded during concreting)

Material: Stainless steel 1.4301

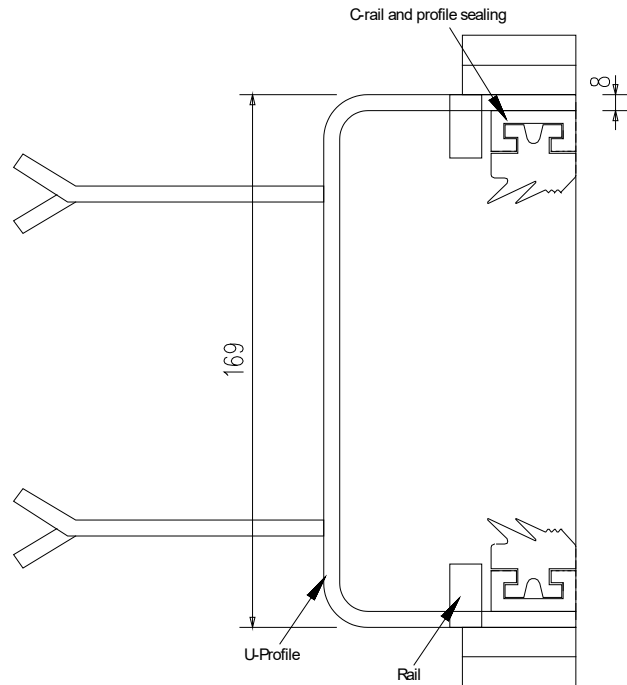

Wall connecting post  
End post 80 x 169

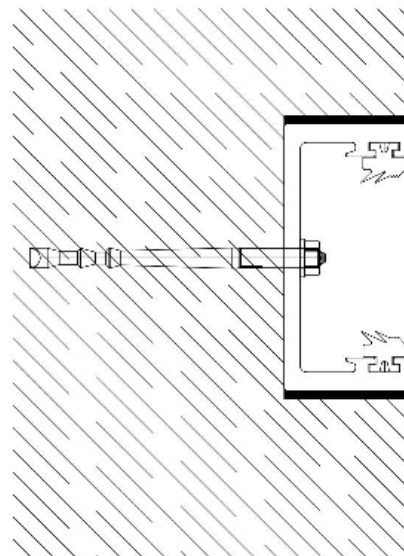
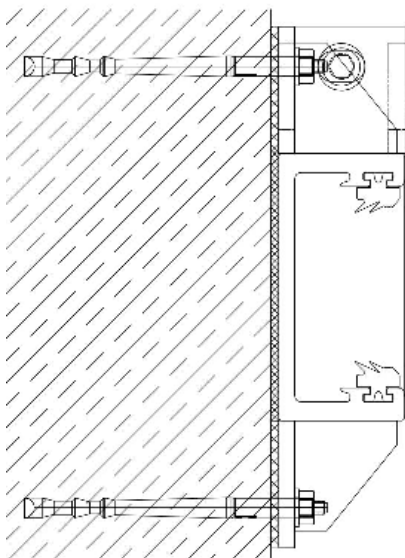

Technical data

Moment of inertia	I	1611 cm <sup>4</sup>
Section modulus	W	191 cm <sup>3</sup>
Cross section	A	37.47 cm <sup>2</sup>
Weight		10.1 kg/m
Material		EN AW-6082 T6

Corner post 90° with endpost profile  
Standard corner post

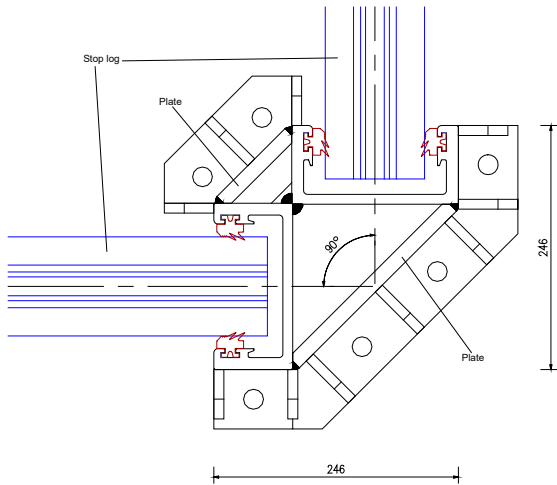

Corner post 90° with post MP 240x180  
Special corner post for large force impact

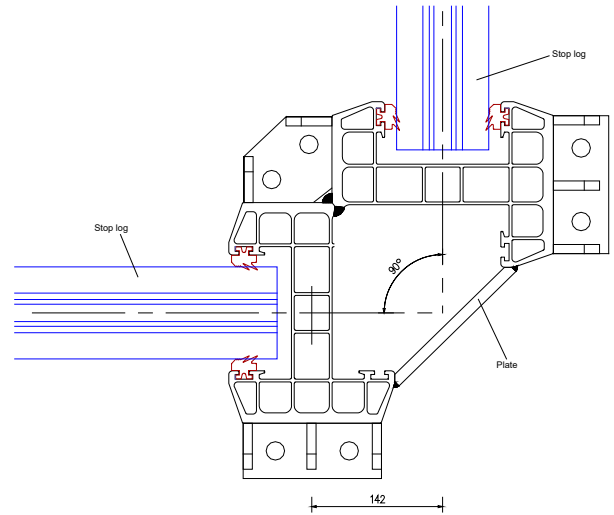

Anchor plate: 90° post

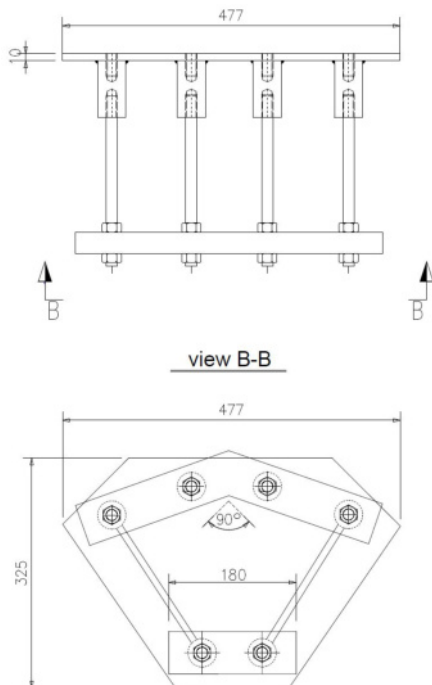

Anchor plate: 90° for corner post  
MP 240/180

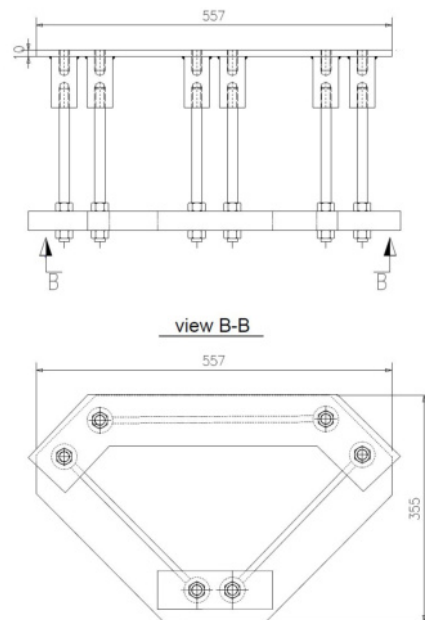

Steel grades

Stainless steel	1.4301	Top plate / Threaded sleeve
Steel	S 355	Connecting plate
Steel	8.8	Threaded bolts / Nuts

Steel grades

Stainless steel	1.4301	Top plate / Threaded sleeve
Steel	S 355	Connecting plate
Steel	8.8	Threaded bolts / Nuts



Pocket  
Hot dip galvanized steel S355

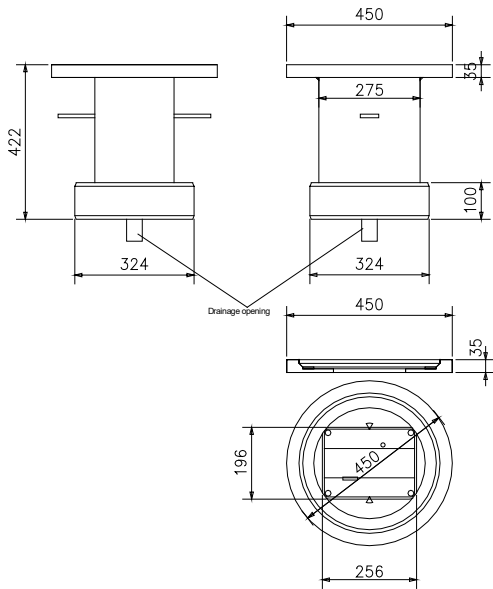

Pocket cover  
Hot dip galvanized steel S355

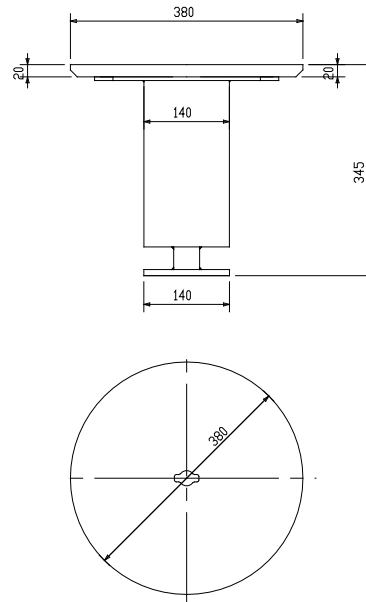

Fast construction post with pocket

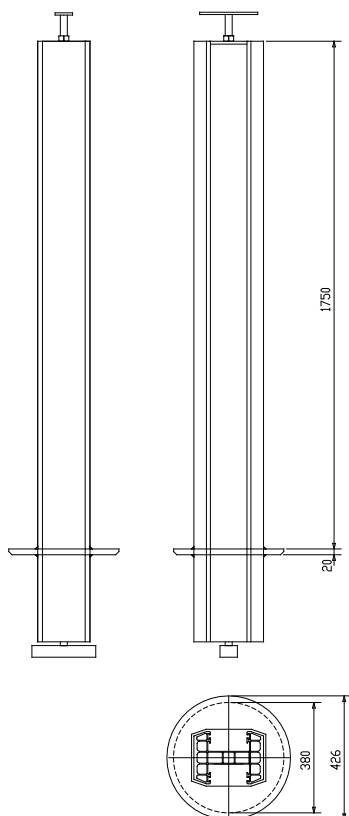

Steel grades

Aluminum	Post EN AW 6063 T66
Weight	approx. 37.50 kg/m
Steel	Locking S 355

Special system: Connection to sheet pile without cladding system

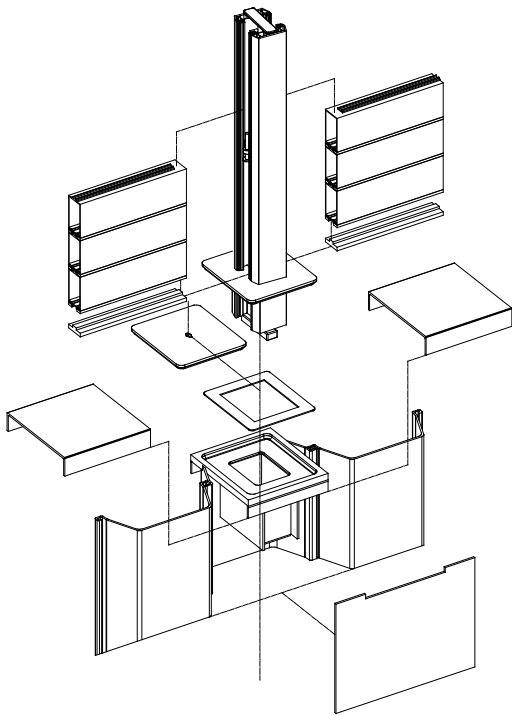

Special system: Connection to sheet pile with cladding system

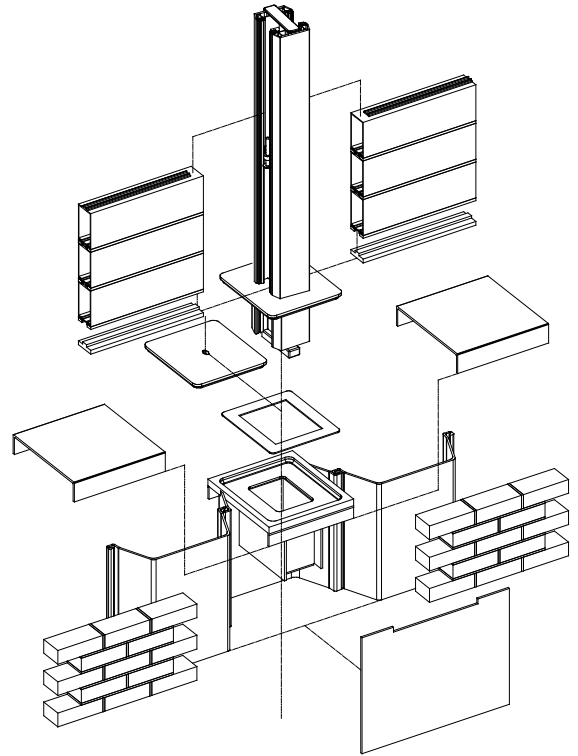

## Special system: Connection to sheet pile (wall details)

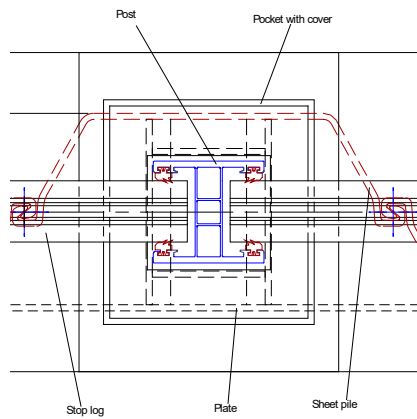
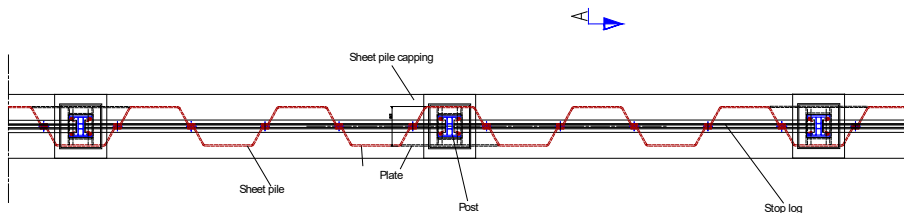
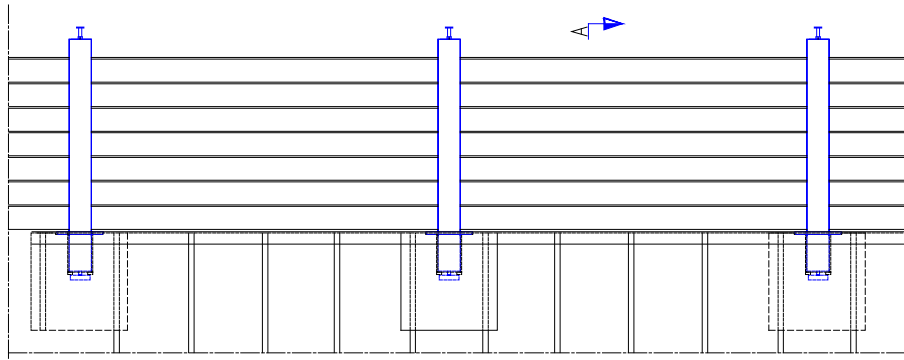

View pocket with locking

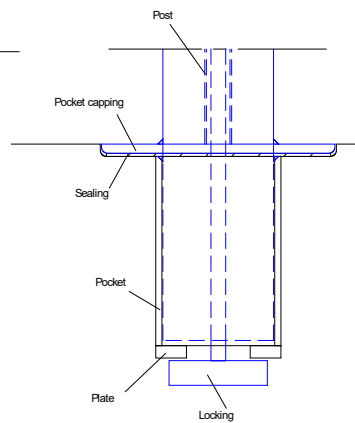

Cross section A-A

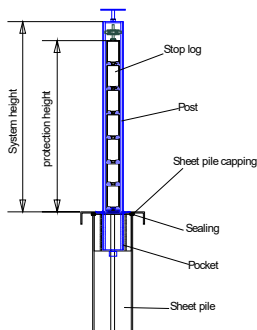

## Sealing system

### Base seal

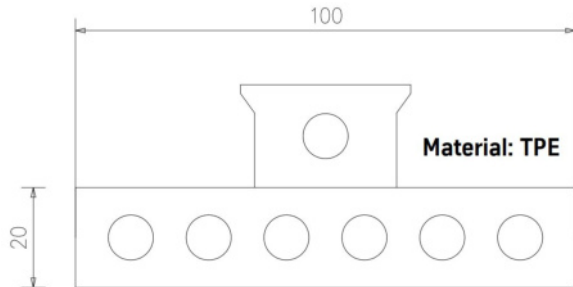

### Post seal

### Stop log seal

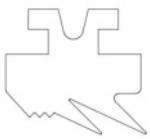

Material: EPDM

## Locking system

Material: Stainless steel 1.4301

Use for all posts and wall connectors of System terra tk 100

Use only with stainless steel wall connectors on page 15. Used when a level top edge of wall and stop log is required. It is not suitable in posts area.

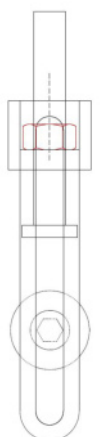
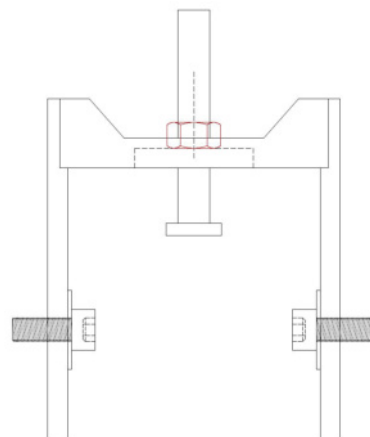
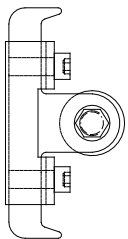
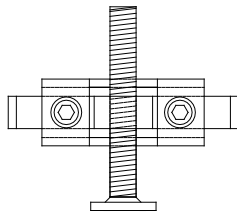
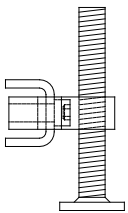

terra infrastructure GmbH, Hollestr. 7a, 45127 Essen, Germany  
T: +49 201 5657832110  
info@terra-infrastructure.com | www.terra-infrastructure.com

### **Australia**

terra infrastructure Pty Ltd, 11 Woodford Pl, Thornton NSW 2322, Australia  
P: +61 2 8448-3555  
Info.anz@terra-infrastructure.com  
www.terra-infrastructure.com.au

### **New Zealand**

terra infrastructure Pty Ltd, 180 Fred Taylor Drive, Whenuapai Auckland 0814, New Zealand  
P: +64 9 416-8891  
Info.anz@terra-infrastructure.com  
www.terra-infrastructure.co.nz

### **Baltic States**

terra infrastructure UAB, Liepų g. 83, 93269 Klaipėda, Lithuania  
P: +370 46 355-401  
www.terra-infrastructure.com/lt

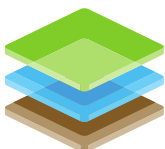

terra  
infrastructure