



ANCHOR AND MICROPILE EQUIPMENT TECHNICAL HANDBOOK

SOLUTIONS FOR ALL CHALLENGES

Our anchors and micropiles are used in construction projects such as quays, foundations for onshore and offshore wind generators, tunnels, excavation pits, retaining walls and slope stabilization. We have an extensive product range that can be used to solve a wide variety of challenges.

Content

02	Anchor and Micropiles
02	Round steel tie rods
06	terra ASF micropile

Anchor equipment

Round steel tie rods

Round steel tie rod components and connecting elements

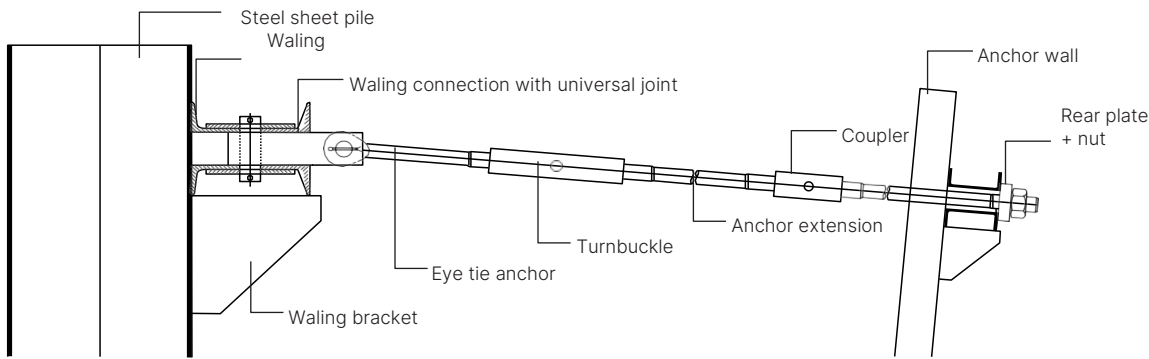

*Accessory parts as shown above on request

Anchor with upset ends – rolled thread

Round steel tie rods acc. to DIN EN 1993-5 and EAU 2020

Anchor force according to DIN EN 1993-5 - $k_t = 0.60$		M39	M42	M45	M48	M52	M56	M60	M64	M68	M72	M76	M80	M85	M90
Nominal diameter	D mm	39	42	45	48	52	56	60	64	68	72	76	80	85	90
Shaft diameter	d mm	36	39	42	45	49	52	56	60	64	68	72	76	81	86
Tensile stress area Thread	As mm ²	976	1,121	1,306	1,473	1,758	2,030	2,362	2,676	3,055	3,460	3,889	4,344	4,948	5,591
Cross sectional area Shaft	Ag mm ²	1,017	1,194	1,385	1,590	1,847	2,124	2,463	2,827	3,217	3,632	4,072	4,536	5,153	5,809
ASF 355 Permissible design resistance	Rd kN	346	398	464	523	624	721	839	950	1,085	1,228	1,381	1,542	1,757	1,985
ASF 460 Permissible design resistance	Rd kN	449	516	601	678	809	934	1,087	1,231	1,405	1,592	1,789	1,998	2,276	2,572
ASF 500 Permissible design resistance	Rd kN	478	549	639	721	861	994	1,156	1,310	1,496	1,694	1,904	2,127	2,423	2,737
ASF 720 Permissible design resistance	Rd kN	632	726	846	955	1,139	1,315	1,531	1,734	1,980	2,242	2,520	2,815	3,206	3,623
Weight (Shaft)	G kg/m	7.99	9.38	10.88	12.49	14.80	16.62	19.34	22.20	25.25	28.51	31.96	35.61	40.45	45.60

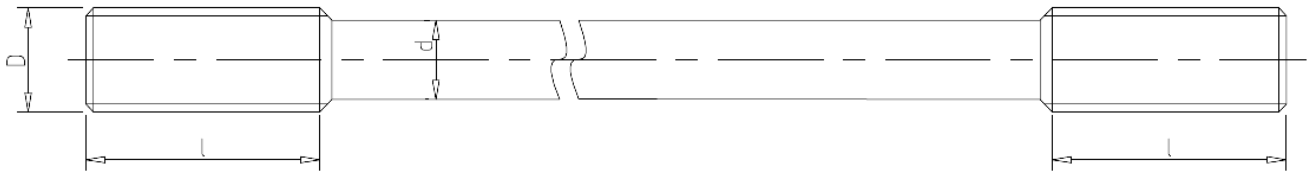

Anchor force according to DIN EN 1993-5 - $k_t = 0.60$		M95	M100	M105	M110	M115	M120	M125	M130	M135	M140	M145	M150	M155	M160
Nominal diameter	D mm	95	100	105	110	115	120	125	130	135	140	145	150	155	160
Shaft diameter	d mm	91	96	101	106	111	116	121	126	131	136	141	146	151	156
Tensile stress area Thread	As mm ²	6,273	6,995	7,755	8,556	9,395	10,274	11,191	12,149	13,145	14,181	15,256	16,370	17,524	18,716
Cross sectional area Shaft	Ag mm ²	6,504	7,238	8,012	8,825	9,677	10,568	11,499	12,469	13,478	14,527	15,615	16,742	17,908	19,113
ASF 355 Permissible design resistance	Rd kN	2,227	2,483	2,753	3,037	3,335	3,647	3,973	4,313	4,666	5,034	5,416	5,811	6,221	6,644
ASF 460 Permissible design resistance	Rd kN	2,886	3,218	3,567	3,936	4,322	4,726	5,148	5,589	6,047	6,523	7,018	7,530	8,061	8,609
ASF 500 Permissible design resistance	Rd kN	3,071	3,425	3,797	4,189	4,600	5,030	5,479	5,948	6,436	6,943	7,469	8,015	8,580	9,163
ASF 720 Permissible design resistance	Rd kN	4,065	4,533	5,025	5,544	6,088	6,658	7,252	7,873	8,518	9,189	9,886	10,608	11,356	12,128
Weight (Shaft)	G kg/m	51.06	56.82	62.89	69.27	75.96	82.96	90.27	97.88	105.80	114.04	122.57	131.42	140.58	150.00

Anchor with rolled thread

Anchor force according to DIN EN 1993-5 - kt = 0.90			M 39	M 42	M 45	M 48	M 52	M 56	M 60	M 64	M 68	M 72	M 76	M 80	M 85	M 90
Nominal diameter	D	mm	39	42	45	48	52	56	60	64	68	72	76	80	85	90
Shaft diameter	d	mm	36	39	42	45	49	52	56	60	64	68	72	76	81	86
Tensile stress area Thread	As	mm ²	976	1,121	1,306	1,473	1,758	2,030	2,362	2,676	3,055	3,460	3,889	4,344	4,948	5,591
Cross sectional area Shaft	Ag	mm ²	1,017	1,194	1,385	1,590	1,847	2,124	2,463	2,827	3,217	3,632	4,072	4,536	5,153	5,809
ASF 355 Permissible design resistance	Rd	kN	346	398	464	523	624	721	839	950	1,085	1,228	1,381	1,542	1,757	1,985
ASF 460 Permissible design resistance	Rd	kN	449	516	601	678	809	934	1,087	1,231	1,405	1,592	1,789	1,998	2,276	2,572
ASF 500 Permissible design resistance	Rd	kN	478	549	639	721	861	994	1,156	1,310	1,496	1,694	1,904	2,127	2,423	2,737
ASF 720 Permissible design resistance	Rd	kN	632	726	846	955	1,139	1,315	1,531	1,734	1,980	2,242	2,520	2,815	3,206	3,623
Weight (Shaft)	G	kg/m	7.99	9.38	10.88	12.49	14.80	16.62	19.34	22.20	25.25	28.51	31.96	35.61	40.45	45.60

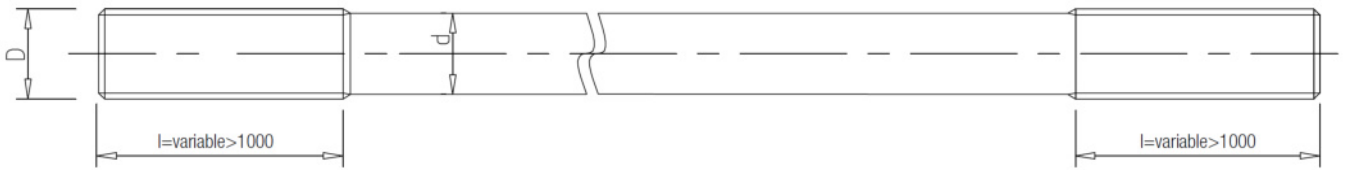

Anchor force according to DIN EN 1993-5 - kt = 0.90			M 95	M 100	M 105	M 110	M 115	M 120	M 125	M 130	M 135	M 140	M 145	M 150	M 155	M 160
Nominal diameter	D	mm	95	100	105	110	115	120	125	130	135	140	145	150	155	160
Shaft diameter	d	mm	91	96	101	106	111	116	121	126	131	136	141	146	151	156
Tensile stress area Thread	As	mm ²	6,273	6,995	7,755	8,556	9,395	10,274	11,191	12,149	13,145	14,181	15,256	16,370	17,524	18,716
Cross sectional area Shaft	Ag	mm ²	6,504	7,238	8,012	8,825	9,677	10,568	11,499	12,469	13,478	14,527	15,615	16,742	17,908	19,113
ASF 355 Permissible design resistance	Rd	kN	2,227	2,483	2,753	3,037	3,335	3,647	3,973	4,313	4,666	5,034	5,416	5,811	6,221	6,644
ASF 460 Permissible design resistance	Rd	kN	2,886	3,218	3,567	3,936	4,322	4,726	5,148	5,589	6,047	6,523	7,018	7,530	8,061	8,609
ASF 500 Permissible design resistance	Rd	kN	3,071	3,425	3,797	4,189	4,600	5,030	5,479	5,948	6,436	6,943	7,469	8,015	8,580	9,163
ASF 720 Permissible design resistance	Rd	kN	4,065	4,533	5,025	5,544	6,088	6,658	7,252	7,873	8,518	9,189	9,886	10,608	11,356	12,128
Weight (Shaft)	G	kg/m	51.06	56.82	62.89	69.27	75.96	82.96	90.27	97.88	105.80	114.04	122.57	131.42	140.58	150.00

Permissible design resistances Rd according to DIN 1993-5 (D) / Stressed area

Round steel tie rods and bolts

(The threads - Metric thread - are rolled up)

The design resistances are calculated using the following equation over the minimum cross section:

$$F_{t,Rd} = \begin{matrix} \text{(Shaft cross section)} & A_g \times f_{y,k} / \gamma_{M0} & A_{\text{Shaft}} \times f_{y,k} / \gamma_{M0} & \text{where } \gamma_{M0} = 1.00 \\ \text{(Thread cross section)} & k_t \times A_s \times f_{ub,k} / \gamma_{M2} & k_t \times A_{Sp} \times f_{ub,k} / \gamma_{M2} & \text{where } \gamma_{M2} = 1.25 \end{matrix}$$

Verification for the ultimate limit state to DIN EN 1993-5:

$Z_d < R_d$		$f_{y,k}$:	yield stress
Z_d :	design value of anchor force $Z_d = Z_{0,k} * \gamma_G + Z_{0,k} * \gamma_Q$	$f_{ub,k}$:	tensile strength
R_d :	design resistance of anchor $R_d = \text{Min} [F_{t,Rd} ; F_{t,Rd}]$	γ_{M0} :	partial safety factor to DIN EN 1993-5 for anchor shaft
A_g :	cross-sectional area in shaft zone	γ_{M2} :	partial safety factor to DIN EN 1993-5 for threaded area
A_s :	tensile stress area in threaded zone	k_t :	notch factor to DIN 1993-5 ($k_t = 0.60$ or 0.90)

Eye anchor

ASF 355 anchor force acc. to DIN EN 1993-5 with $k_t = 0.6$		A150	A175	A200	A200	A225	A225	A225	A250	A275	A300A	A300B	A325	A350	A375A
Shaft diameter	d mm	36	39	42	42	45	45	45	48	52	56	60	64	68	72
Thickness eye	c mm	25	30	33	33	39	39	39	42	47	50	50	55	60	63
Length eye	La mm	86	106	127	127	135	135	135	147	166	190	190	210	220	235
Width eye	a mm	72	85	105	105	110	110	110	125	135	155	155	165	180	190
Bolt diameter	d0 mm	30	33	36	36	40	40	40	47	52	56	56	62	68	70

ASF 355 anchor force acc. to DIN EN 1993-5 with $k_t = 0.6$		A375B	A400	A425	A450	A450	A475	A500	A525	A550	A575	A575	A600	A625	A650
Shaft diameter	d mm	75	80	85	90	90	95	100	105	110	115	115	120	125	130
Thickness eye	c mm	63	66	72	75	75	80	85	90	95	100	100	105	115	120
Length eye	La mm	235	253	290	300	300	323	340	350	365	373	373	380	439	459
Width eye	a mm	190	210	230	240	240	255	270	275	290	300	300	310	330	340
Bolt diameter	d0 mm	70	76	80	85	85	90	95	100	100	105	105	110	115	120

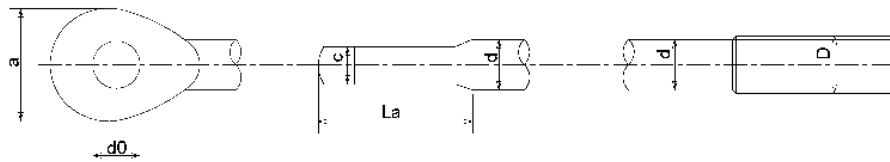

ASF 500 anchor force acc. to DIN EN 1993-5 with $k_t = 0.6$		A150	A175	A200	A200	A225	A225	A225	A250	A275	A300A	A300B	A325	A350	A375A
Shaft diameter	d mm	36	39	42	42	45	45	45	48	52	56	60	64	68	72
Thickness eye	c mm	25	30	33	33	39	39	39	42	47	50	50	55	60	63
Length eye	La mm	86	106	127	127	135	135	135	147	166	190	190	210	220	235
Width eye	a mm	72	85	105	105	110	110	110	125	135	155	155	165	180	190
Bolt diameter	d0 mm	30	33	36	36	41	41	41	47	52	56	56	62	68	70

ASF 500 anchor force acc. to DIN EN 1993-5 with $k_t = 0.6$		A375B	A400	A425	A450	A450	A475	A500	A525	A550	A575	A575	A600	A625	A650
Shaft diameter	d mm	75	80	85	90	90	95	100	105	110	115	115	120	125	130
Thickness eye	c mm	63	66	72	75	75	80	85	90	95	100	100	105	115	120
Length eye	La mm	235	253	290	300	300	323	340	350	365	373	373	380	439	459
Width eye	a mm	190	210	230	240	240	255	270	275	290	300	300	310	330	340
Bolt diameter	d0 mm	70	76	80	85	85	90	95	100	105	110	110	115	120	125

ASF 720 anchor force acc. to DIN EN 1993-5 with $k_t = 0.6$		A150	A175	A200	A200	A225	A225	A225	A250	A275	A300A	A300B	A325	A350	A375A
Shaft diameter	d mm	36	39	42	42	45	45	45	48	52	56	60	64	68	72
Thickness eye	c mm	25	30	33	33	39	39	39	42	47	50	50	55	60	63
Length eye	La mm	86	106	127	127	135	135	135	147	166	190	190	210	220	235
Width eye	a mm	72	85	105	105	110	110	110	125	135	155	155	165	180	190
Bolt diameter	d0 mm	30	33	40	40	44	44	44	50	55	61	61	66	72	76

ASF 720 anchor force acc. to DIN EN 1993-5 with $k_t = 0.6$		A375B	A400	A425	A450	A450	A475	A500	A525	A550	A575	A575	A600	A625	A650
Shaft diameter	d mm	75	80	85	90	90	95	100	105	110	115	115	120	125	130
Thickness eye	c mm	63	66	72	75	75	80	85	90	95	100	100	105	115	120
Length eye	La mm	235	253	290	300	300	323	340	350	365	373	373	380	439	459
Width eye	a mm	190	210	230	240	240	255	270	275	290	300	300	310	330	340
Bolt diameter	d0 mm	76	85	90	95	95	100	105	110	110	115	115	125	130	135

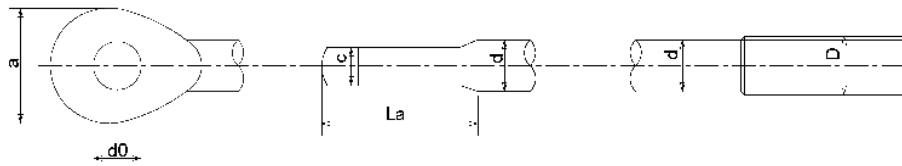

terra ASF micropile

General information

The terra ASF micropile is a system according to DIN 14199 and DIN SPEC 18539. A main feature of the terra ASF micropile is the use of a good-tolerance steel grade. As a result, the system has low steel elongation under load and higher load-bearing reserves than comparable micropile systems. Currently, micropiles with a length of up to 34 meters can be supplied in one piece.

Corrosion protection

Permanent corrosion protection is ensured with the help of the cement stone covering of the grout body. The use of an additional grouted corrugated sheathing, as in comparable systems, is not necessary. The permanent corrosion protection of the pile head is achieved either by placing the pile head in concrete or by using the pile head construction in accordance with the approval.

Intended purpose

Micropile for tie-back anchoring

- According to DIN EN 14199 for load transfer of tensile loads into deeper, load-bearing soil layers

Micropile for foundations

- According to DIN EN 14199 for load transfer of compressive and tensile loads in deeper, load-bearing soil layers

Nominal size		Inch	3	3½	4	4¼
Outer diameter	Ø	mm	71.0	83.0	96.0	102.0
Cross-sectional area	A	cm ²	37.0	51.3	67.7	77.3
Yield strength/tensile strength	fy/fu	N/mm ²	500/700	500/700	500/700	500/700
Characteristic load-bearing capacity for tensile load ¹⁾	R _k	kN	2,036	2,598	3,385	4,139
Characteristic load-bearing capacity under compressive load ¹⁾	R _k	kN	2,127	2,598	3,385	4,242
Elongation stiffness	E · A	MN	611	912	1,365	1,650
Weight		kg/m	31.1	42.5	56.8	64.1

1. Utilization of the load-bearing capacity is dependent on the cement stone cover according to approval Z-34.14-243

2. The use of the terra ASF micropile are regulated in Germany by the National Technical Approval Z-34.14-243 issued by the German Institute for Civil Engineering (DIBt)

Dimensioning

The verification of the internal and external load-carrying capacity must always be performed out when micropiles are used as a tie-back anchorage or as an foundation pile. Further verifications such as the buckling analysis and the serviceability analysis may be required depending on the intended use.

Verification of the load-carrying capacity of the pile materials

The verification of the load-carrying capacity of the pile material proves that the design value of actions E_d is less than the design value of the pile resistance. The verification of the load-carrying capacity of the pile materials is carried out as follows:

Design value of actions (E_d) ≤ design value of pile resistance (R_d)

where:

$$E_d = \gamma_G * G_k + \gamma_Q * Q_k$$

$$R_d = R_k / \gamma_M$$

with

E_d	Design value of actions
γ_G	Partial safety factor for permanent actions
	= 1.35 for BS-P (constant situation)
	= 1.20 for BS-T (temporary situation)
γ_Q	Partial safety factor for variable actions
	= 1.50 for BS-P (constant situation)
	= 1.30 for BS-T (temporary situation)
R_d	Design value of the pile resistance
R_k	Characteristic load capacity
γ_M	Partial safety factor Material resistance
	= 1.15 for BS-P, BS-T und BS-A

Verification of the external load carrying capacity of the grout/soil friction

Micropiles transfer loads to the soil via the skin friction. For this purpose, it must be ensured that the surface of the grout body is sufficiently large enough. The required surface area is determined by the diameter and length of the grout body and the skin friction value $q_{s,i,k}$, of the soil layer.

With the help of site investigations and pile test, the actually existing skin friction value of the existing soils can be determined.

Alternatively, the design of the external load-carrying capacity can be performed with the empirical values of the skin friction according to EA-Piles Tab. 5.29 und 5.30.

Application example deep foundation

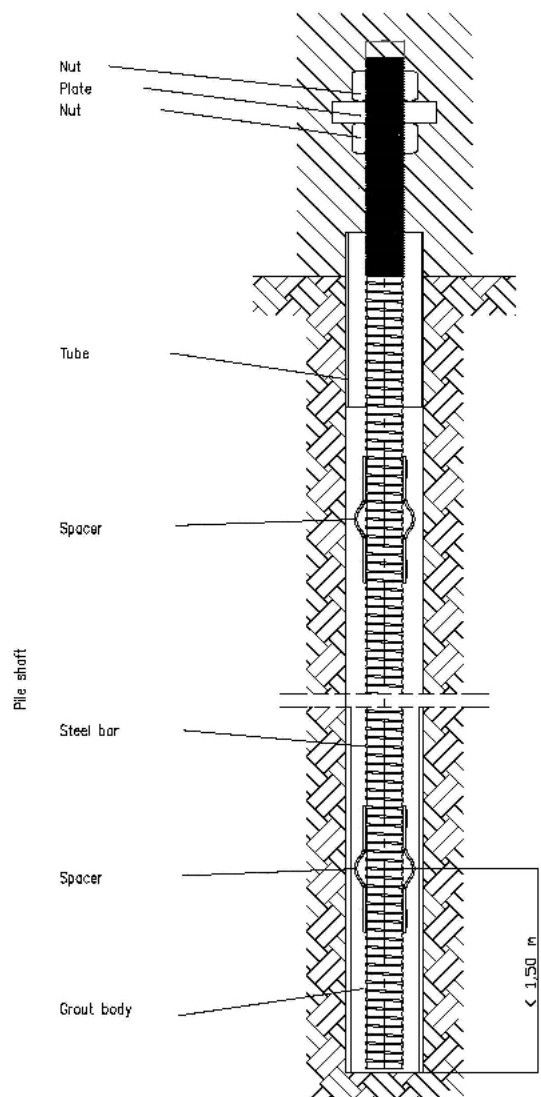

Permanent pile head construction in detail according to Approval Z-34.14-243

In the case of tie-back anchoring of a sheet pile or combination wall, installation of the pile head in concrete is not always wanted or possible. For this reason, a pile head construction was developed for the thyssenkrupp ASF drilled injection pile that allows the permanent use (100+ years).

For the planning of the micropile, the required dimensions of the pile head-construction can be taken from the approval. The additional verification of the plates, the pipe sockets and the weld seams can be omitted. Because of this the planning of the micropiles can be performed more quickly and efficiently

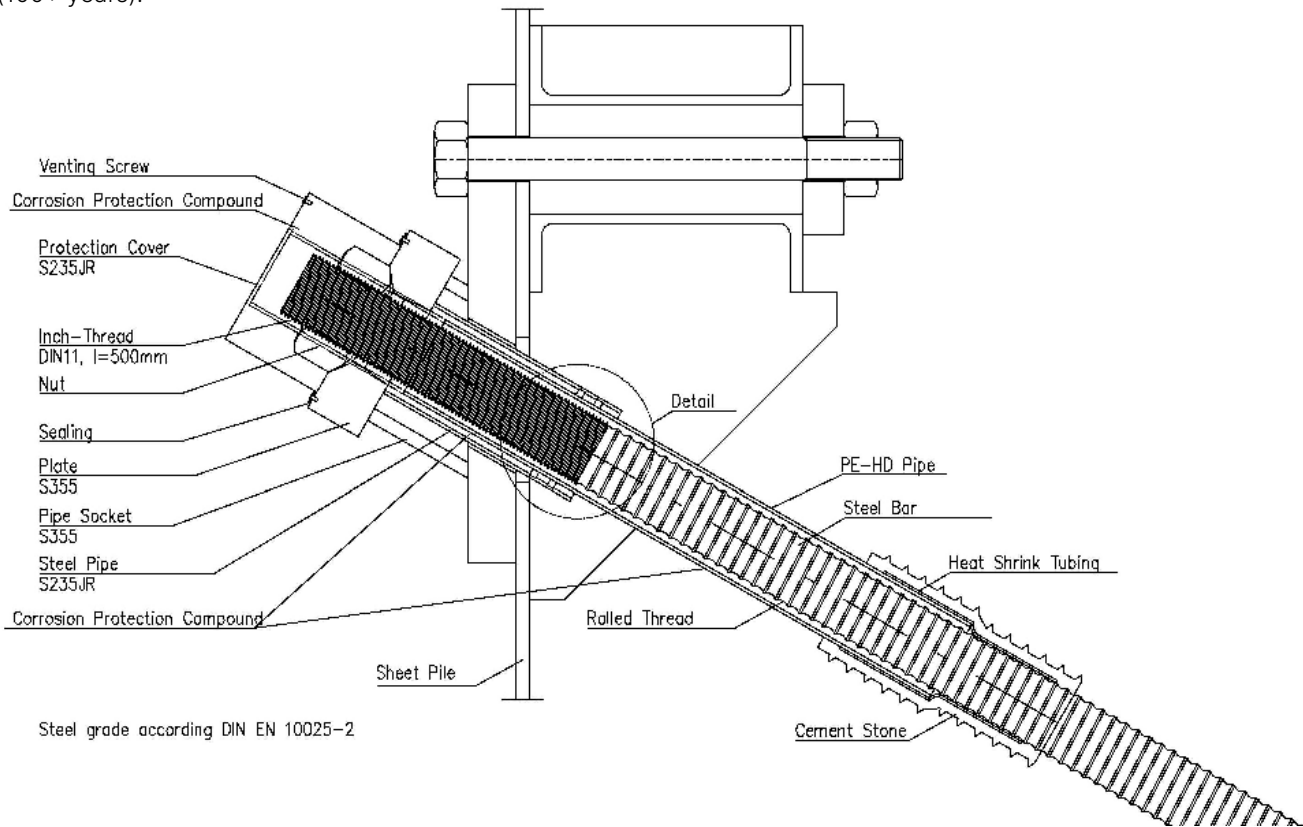

terra infrastructure GmbH, Hollestr. 7a, 45127 Essen, Germany
T: +49 201 5657832110
info@terra-infrastructure.com | www.terra-infrastructure.com

Australia

terra infrastructure Pty Ltd, 11 Woodford Pl, Thornton NSW 2322, Australia
P: +61 2 8448-3555
Info.anz@terra-infrastructure.com
www.terra-infrastructure.com.au

New Zealand

terra infrastructure Pty Ltd, 180 Fred Taylor Drive, Whenuapai Auckland 0814, New Zealand
P: +64 9 416-8891
Info.anz@terra-infrastructure.com
www.terra-infrastructure.co.nz

Baltic States

terra infrastructure UAB, Liepų g. 83, 93269 Klaipėda, Lithuania
P: +370 46 355-401
www.terra-infrastructure.com/lt

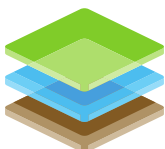

terra
infrastructure